

## Description:

The **Warthog WS-1/2** Rotary Sewer Nozzle was designed for cleaning 4 to 6 inch pipes and sewer lines with elbows. Jet thrust powers rotation of the head and pulls the tool thru the line. The WS has a 2 foot hose attached directly to the inlet, with a 1/2 npt female thread on the other end. This flexible arrangement allows the tool to go around elbows and enter through cleanouts. We recommend not using the tool in 3 inch lines with elbows, as the tool might pass thru, but it may not be possible to pull it back. A Super Centralizer (WS 084) is available for use when cleaning larger pipe sizes; it is 4.5" diameter.

The swivel is a straight flow through design with a single high pressure seal. The WS is capable of working pressures up to 4000 psi and flow rates of 7 to 20 gpm, with rotation speeds from 200 to 500 rpm. The unit is filled with a thick viscous fluid that controls the rotation speed.

The nozzle head and nozzle orifice sizes should match the operating conditions of pressure and flow desired. Hose length and size must be known to correctly determine the proper head and orifice sizes. Contact your distributor or [www.sewernozzles.com](http://www.sewernozzles.com) to help in nozzle selection. If the wrong head is used, it may not provide enough torque to rotate the swivel, or it may provide too much torque resulting in excessive rotation speed and rapid seal wear.

## Operation:

Before connecting the tool to the end of the hose, flush the jetter hose to remove debris. Pass hose end through the hose guard or Tiger Tail if one is being used. Attach the tool to the end of the hose; we recommend using teflon tape to seal the threads. Position the tool within the pipe to be cleaned; bring the pump up to pressure, making certain that the Warthog begins to pull it's way in the proper direction into the pipe. Once the pump is up to pressure, feed the Warthog at a reasonable rate to allow the jets to clean the pipe. If roots are present, feeding at a slower rate will improve the cleaning results. Depending on the amount of debris in the pipe, it may be necessary to occasionally pull the Warthog back toward the pipe entrance to prevent large buildups behind the tool.

When finished cleaning, shut down and secure pump before removing Warthog from line. Secure the hose reel and Warthog to keep it from dragging on the ground. If the Warthog will be removed from the line and stored for more than several days, blow out water with compressed air to prolong the life of the internal components. **The most important item in maintaining the WS is keeping the tool full of viscous fluid. We recommend that this is done after every 40 to 50 hours of operation. If the tool is spinning much faster than when new, this is an indication that it needs fluid.**



**Do not use the WS in 8 inch or larger pipe sizes, as the tool can turn around and come back toward the operator, causing serious injury or death.**

## Troubleshooting:

**Head will not rotate:** First try rotating head by hand and see if it feels rough or gritty to turn. If it does, the tool must be disassembled and repaired; it likely has bad bearings, seals and fluid. If the tool feels okay, check to see if any nozzles are plugged; even if a nozzle is only partially blocked it can keep the head from rotating. Nozzles must be removed from the head to properly clean them; it does not do any good to poke the material plugging the nozzle back into the head, as it will just replug a nozzle.

**Head spins too fast:** It is likely that the swivel is low on viscous fluid, or the viscous fluid has water in it. The best thing to do is drain all the fluid, wipe the parts clean and refill with the proper fluid. Check that the shaft seals are still good and will keep the fluid from leaking out.

**Seal Leak:** The seal may leak initially at low pressure, but should pop closed as pressure is increased. If operating pressure is reached and the seal is leaking continuously, the high pressure seal may need to be replaced. Refer to the maintenance below.

**Seals wear out quickly:** The tool must be disassembled and inspected. The brass seat should be checked for being installed in the right direction, and it should be replaced any time the high pressure seal is replaced. The bore of the shaft where the high pressure seal is located should be checked for grooving. If it is worn larger than .383", the shaft will need to be replaced.

## Maintenance:

**The most important item in maintaining the WS is keeping the tool full of viscous fluid. We recommend that this is done after every 40 to 50 hours of operation. If the tool is spinning much faster than when new, this is an indication that it needs fluid. \*Blow out all water with compressed air before storing tool!**

### To fill the WS with viscous fluid:

1. Fill the Syringe (BC 410) with viscous fluid. This is best done by unscrewing the handle from the tube and pulling out the plunger. Pour fluid into tube and reassemble.
2. Remove the Port Screw (BJ 026) from the Body. Hold the swivel with the hose tail upward as shown. Thread syringe into port, slowly squeeze fluid into swivel; excess fluid will come out under the weep seal. Keep squeezing in new fluid until it comes out clean.
3. Remove syringe; install Port Screw.

**The WS has a single high pressure seal, located under the Inlet Nut. It should be replaced when water is coming out under the weep seal at operating pressure. (It may leak intermittently at tap pressures; this is normal.)**

### To replace the high pressure seal:

1. Hold Body (WS 003) by flats, unscrew the Inlet Nut (WS 002). Use the flats on Inlet Nut, not the hex on hose end.
2. Remove Seat (RJ 011) and H.P. Seal (RJ 012-TO) from Shaft bore.
3. Apply grease to new H.P. Seal, push into shaft bore until it is flush with the Shaft end.
4. Place flat side of Seat against H.P. Seal; push both in a little bit but not all the way to the bottom.
5. Thread Inlet Nut into Body, tighten to 30 ft-lb.

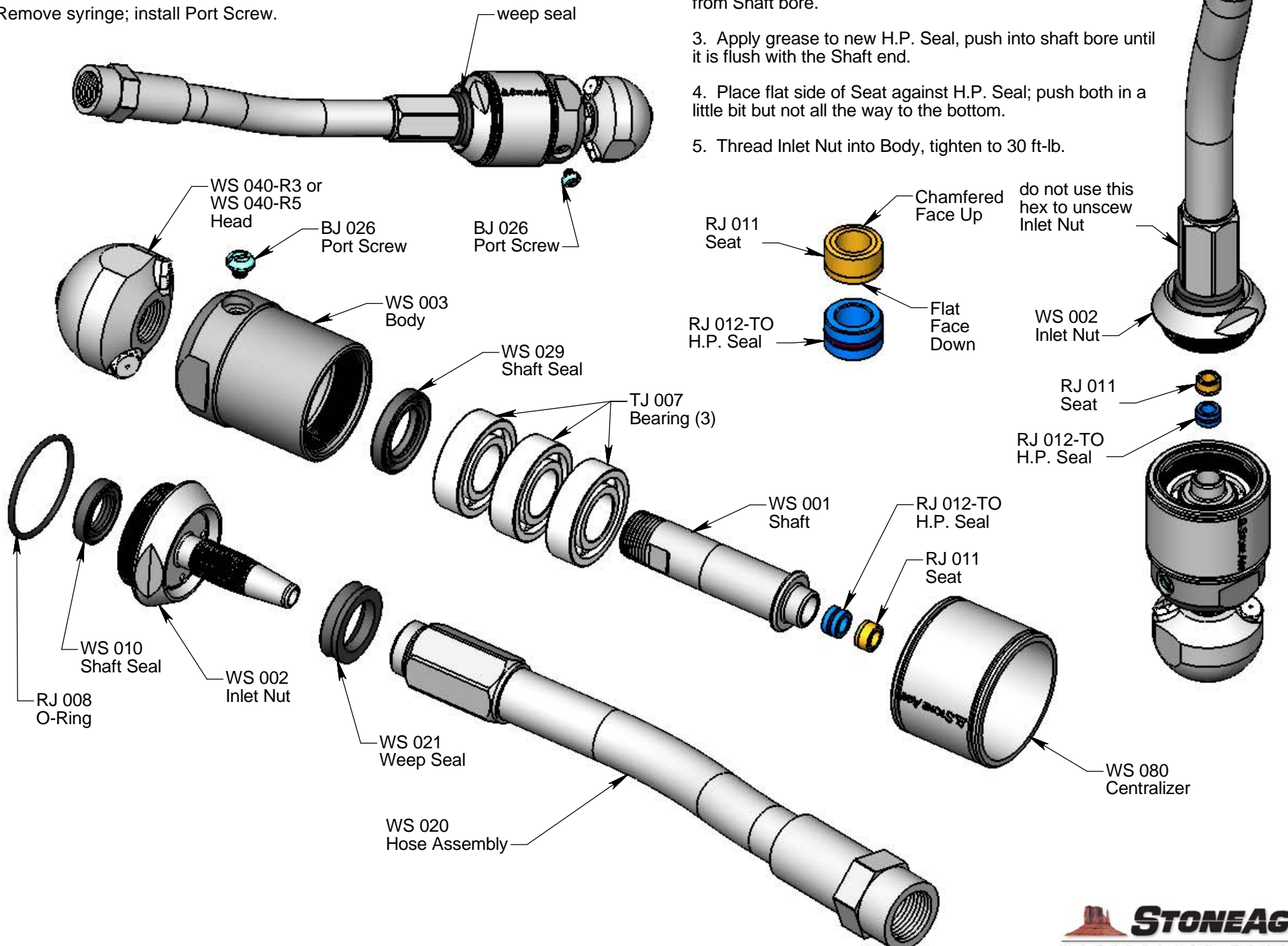

# Warthog WS-1/2 Swivel

## Disassembly:

1. Remove the Head (WS 040) from the Shaft.
2. Unscrew the Inlet Nut (WS 002) from the Body. Use the flats on the Inlet Nut, not the hex on the hose end.
3. Remove the Centralizer (WS 080).
4. Remove the Seat (RJ 011) and H.P. Seal (RJ 012-TO) from the Shaft bore.
5. Push the Shaft (WS 001) with bearings out of Body.
6. Press Shaft (WS 001) out of Bearings (TJ 007). If bearings feel rough to turn, replace them.

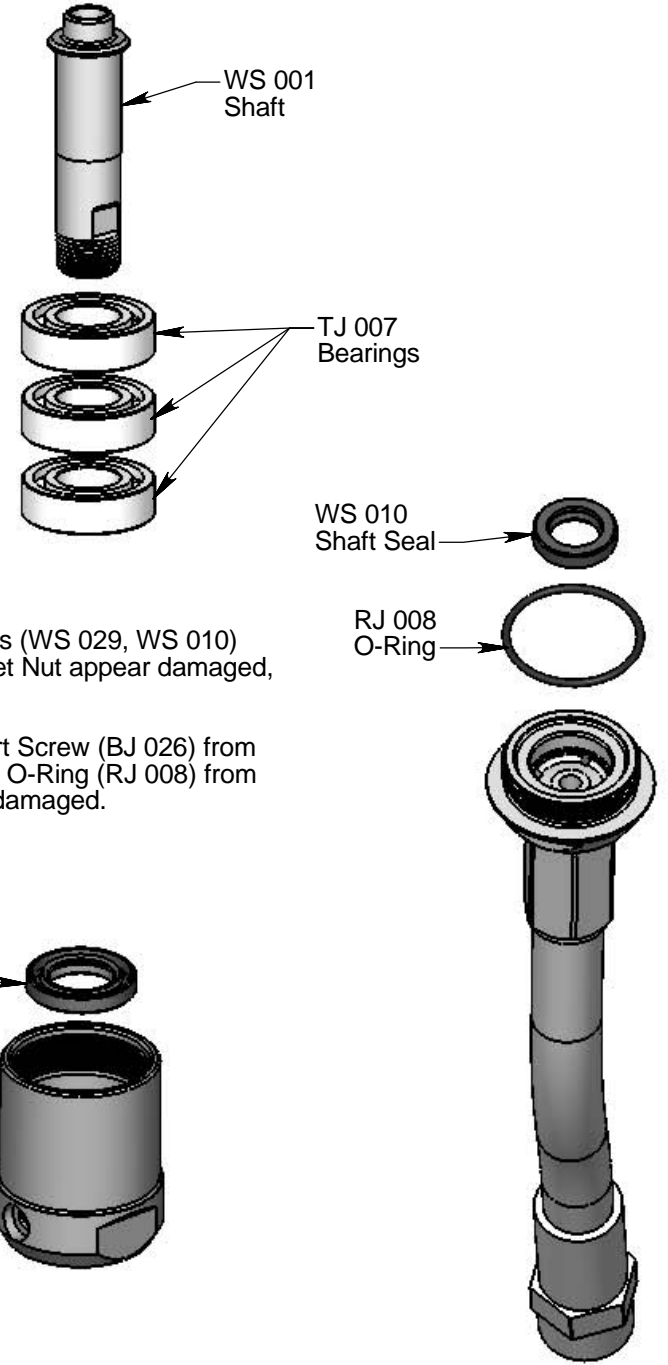
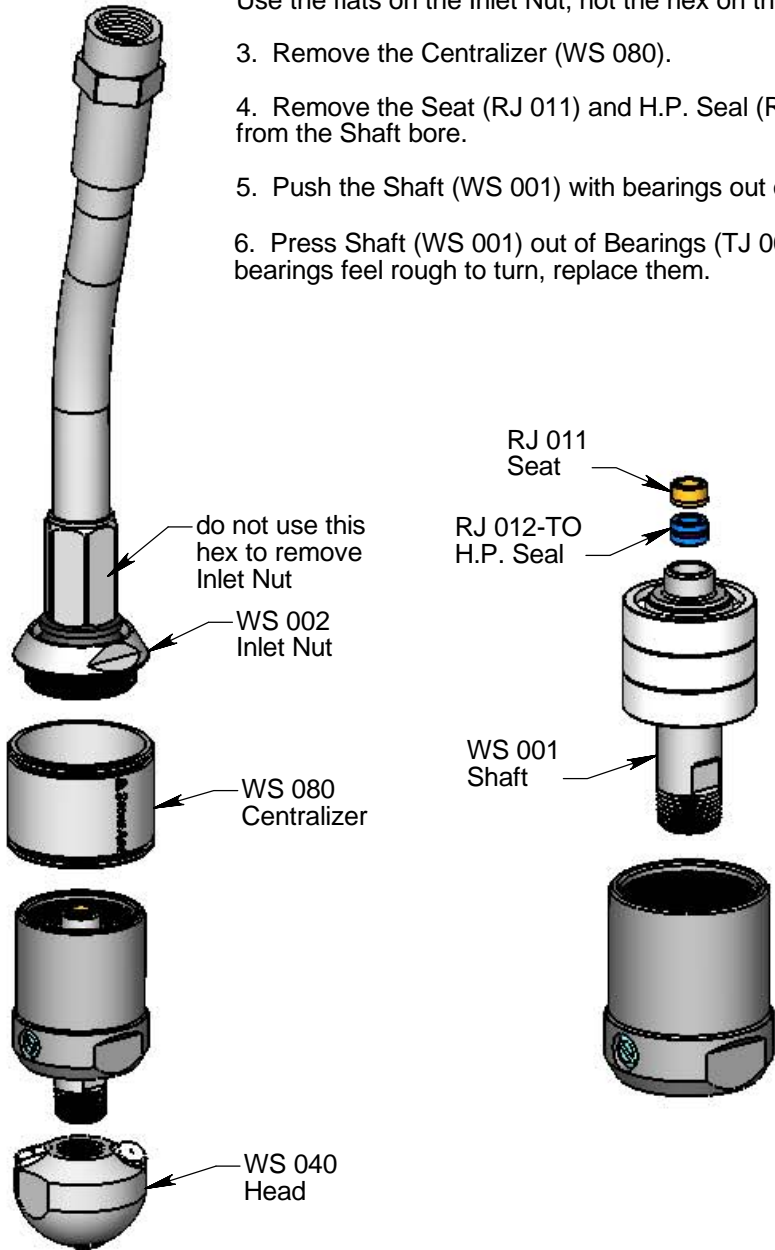

7. If Shaft Seals (WS 029, WS 010) in Body and Inlet Nut appear damaged, remove them.

8. Remove Port Screw (BJ 026) from Body. Remove O-Ring (RJ 008) from Inlet Nut if it is damaged.

## Assembly:

1. Install Shaft Seal (WS 010) in Inlet Nut (WS 002) oriented as shown. Place O-Ring (RJ 008) over threads of Inlet Nut.

2. Install Shaft Seal (WS 029) into Body, oriented as shown.

3. Press the Bearings (TJ 007) one at a time onto the Shaft. It is best to push only on the inner race of the bearing.

4. Push Shaft/bearing stackup into Body. It is easiest to turn the shaft clockwise to thread the pipe threads thru the shaft seal in the Body.

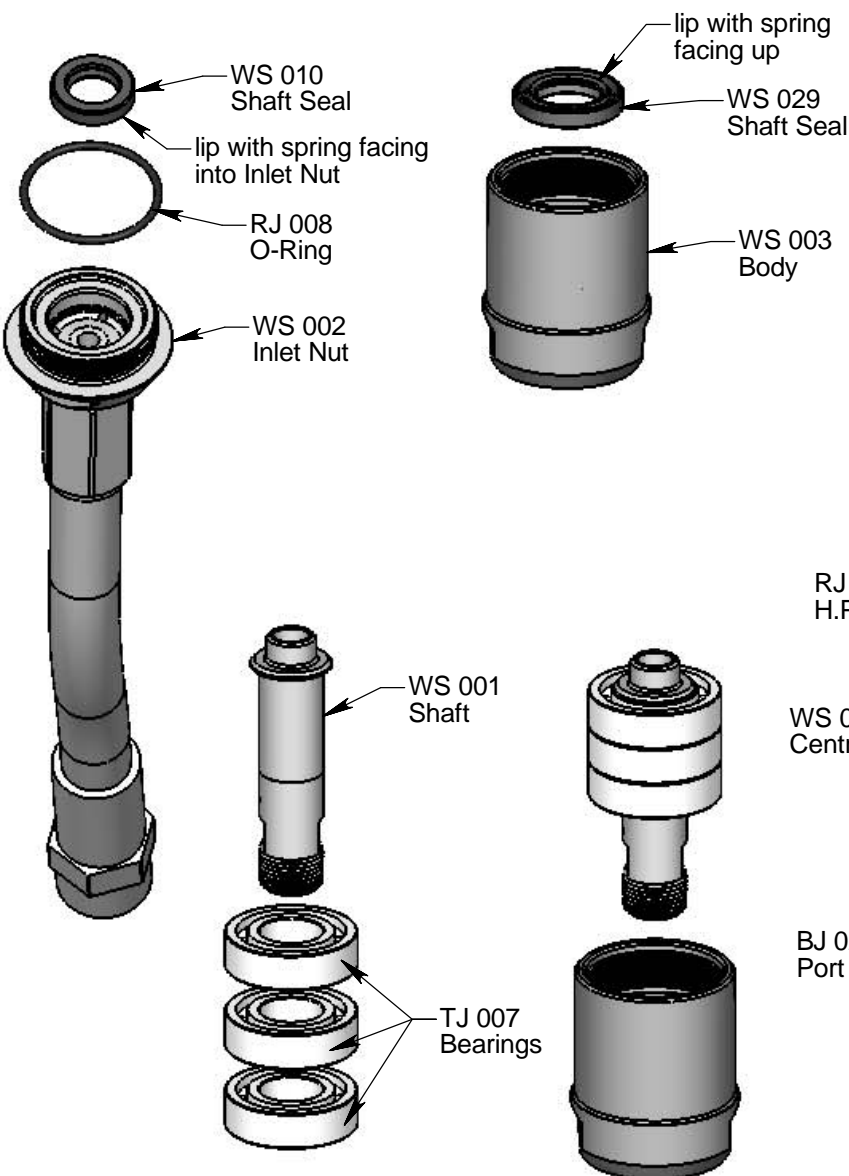

5. Slide Centralizer (WS 080) over the Body.

6. Apply grease to the H.P. Seal (RJ 012-TO) and insert seal into Shaft bore, until flush with end of shaft.

7. Place the Seat (RJ 011) onto the Seal, with the flat face against the seal. (See detail in the Maintenance Section). Push both Seat and Seal a little way into the Shaft bore.

8. Thread Inlet Nut into Body, tighten to 30 ft-lb.

9. Fill tool with syringe as shown in the Maintenance Section; install Port Screw (BJ 026).

The Hose (WS 020) should be replaced if any wire braids are broken or frayed.

1. Unscrew the hose from the Inlet Nut, using the hex on the hose end.

2. Install the Weep Seal (WS 021) on the new hose.

3. Apply lots of oil (10W-40 will work) to the inside of the new hose end and to the nipple on the Inlet Nut.

4. Thread new hose onto nipple, until metal hose end bottoms on face of Inlet Nut.

